

CS SERIES COBOTS

CP SERIES PALLETIZER



ALWAYS EASIER **THAN BEFORE**

Elite Robots is a leading manufacturer of **collaborative robots**, also known as cobots. Founded in 2016, the company has made great strides in the world of robotics, developing an **extensive range of robotic arms and automation solutions** that is constantly being updated and expanded. In line with the company's founding motto (Always Easier than Before), Elite Robots' creations make life easier every day for businesses and individuals around the world for an ever brighter future.

2016
Year founded

300⁺
Employees

200⁺
Patents

15k⁺
Deployed Units



CS SERIES Collaborative Robots Line



Enhanced Safety
27 safety functions
(PL d with Cat. 3
for SF01-SF27;
ISO 13849-1)



Graphic Programming
with expandable
UI supporting
custom plugins
and **application wizards**



Greater Openness
Compatible with
multiple protocols.
24 DI & DO
(8 config.)



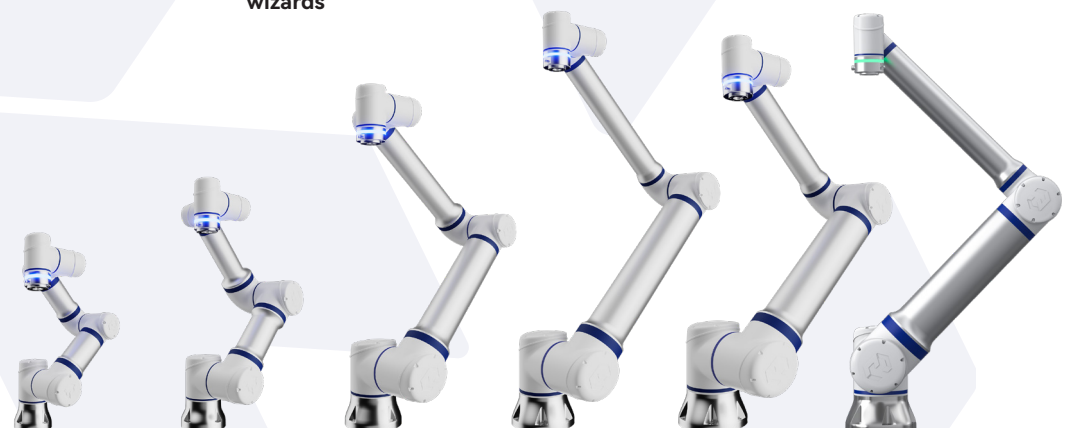

High Ingress Protection
Standard **IP65**
(optional **IP68**)



| | CS63 | CS66 | CS612 | CS620 | CS625 | CS530H* |
|----------------------|------------------|------------------|-------------------|-------------------|-----------------|-------------------|
| Payload | 3 kg / 6.6 lb | 6 kg / 13.2 lb | 12 kg / 26.4 lb | 20 kg / 44 lb | 25 kg / 55.1 lb | 30 kg / 66.1 lb |
| Radius | 624 mm / 24.5 in | 914 mm / 35.9 in | 1304 mm / 51.3 in | 1800 mm / 70.8 in | 1500 mm / 59 in | 1522 mm / 59.9 in |
| Repeatability | ±0.02 mm | ±0.03 mm | ±0.05 mm | ±0.1 mm | ±0.08 mm | ±0.1 mm |
| TCP Speed | 2.0 m/s | 2.8 m/s | 3.4 m/s | 3.9 m/s | 3.3 m/s | 4.0 m/s |

 ISO 13849, ISO 10218

 UL, CE, KCs

 ISO 14644 cleanroom class 5, RoHS

 SEMI-S2

* The CS530H robotic arm can only be supplied as part of the CP series palletizing solution.

CS SERIES

Highlights

Integrated free-drive function

Embedded button for free-drive programming

High output capacity for EOAT

Standard 8-pin connector with capacity up to 3A. Additional 4-pin connector up to 5A for payloads ≥ 20 kg (44 lb). Strong power supply for end effectors.

Lumberg RKMW 8-354 connector

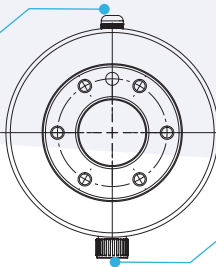

HRS LF10WBRB-4P connector

Safe and for all environments

27 Safety functions:
Compliance with PL d Cat. 3 for SF01-SF27 (ISO 13849-1).
Standard IP65 protection upgradeable to IP68.
ISO class 5 cleanrooms.



EtherNet/IP



Highly Expandable Controller with OEM option

24 DI (8 config.) / 24 DO (8 config.), 4 high-speed digital inputs. Integrated holder to attach the TP for optimal storage.

Optional OEM controller for users who want to create their own custom design.

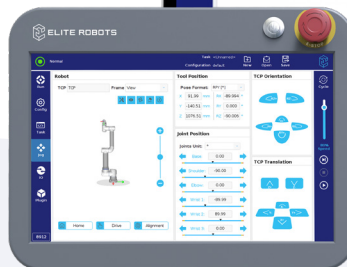

ERP400 Teach-Pendant

12.1" detachable Teach Pendant with full-touch capacitive screen. Optional version (ERP400S) with 3-modes enable key for enhanced safety.

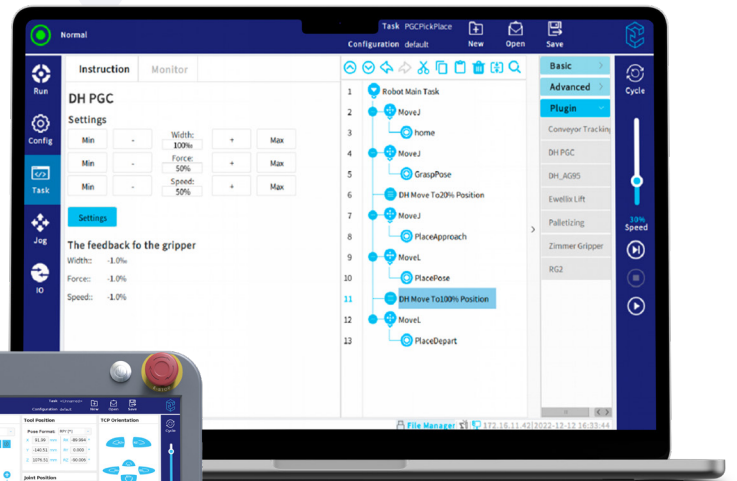

Advanced Software Interface

The CS Series features an intuitive graphical interface for **user-friendly programming via Teach Pendant, laptop and other peripherals.** The highly flexible SDK supports custom plugins, for maximum expandability and customization.

WORKS WITH LEADING PROGRAMMING & SIMULATION PLATFORMS



CP SERIES

All-in-1 Collaborative Palletizing Solution

With a **maximum payload of 30kg (66.1 Lbs)** and a **stacking height of up to 2600mm (102.3 in)**, the Elite Robots **CP (Collaborative Palletizer) Series** is ready to streamline your end-of-line operations. Ensuring a **fast installation** just right of the box, this **cost-effective, safe and easy to use** (no programming skills required) **modular palletizing solution** can accommodate diverse payloads and pallet heights and easily adapt to different customer requirements.



High Payload
Up to **30 Kg / 66.1 Lbs**



High Stacking Height
Up to **2600 mm / 102.3 in**



Up to 20 Boxes/Min
with dual vacuum cup

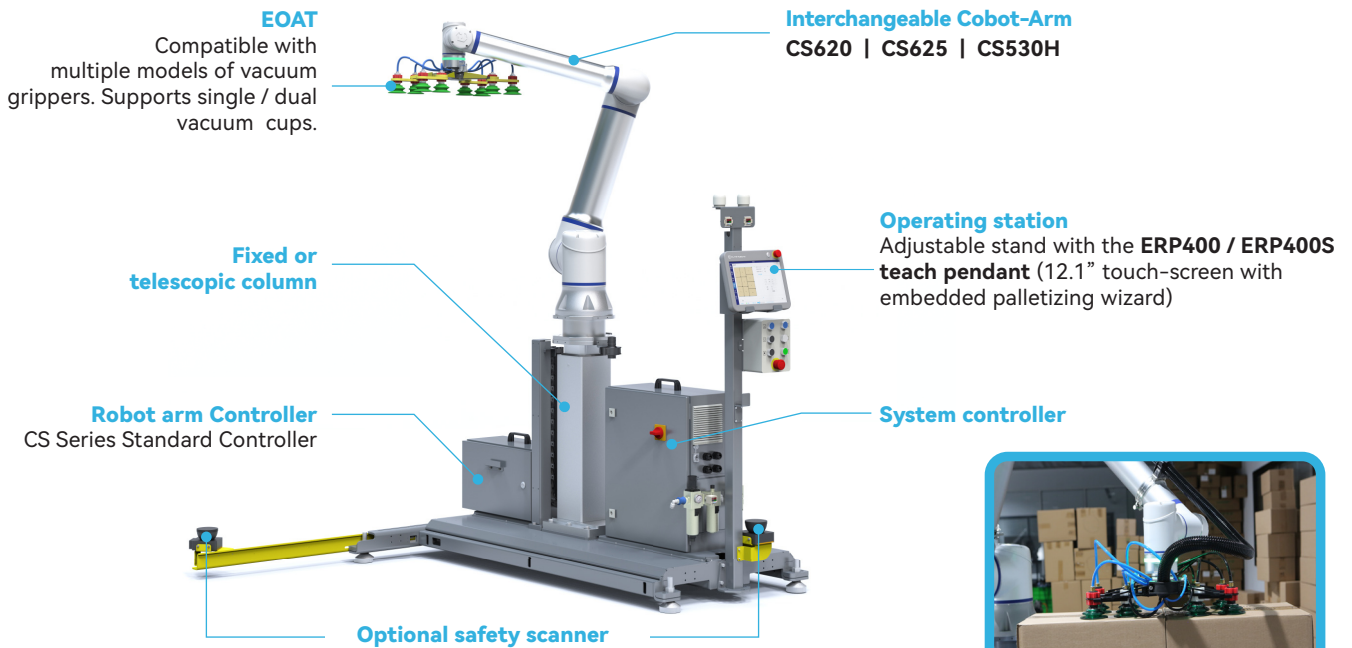

The CP Series in dual-cup mode

Fixed or lifting base column

The combination of the 3 cobot arms with the two alternative base columns (**CPF= Fixed Column; CPL= Lifting Column**) offers a rich selection of variants capable of handling **payloads between 20-30kg (44-66.1 Lbs)**, **pallets up to 1200mm (47.2 in) in length/width** and **stacking height up to 2600mm (102.3 in)**. This makes the CP Series ideal to support applications across various industries.

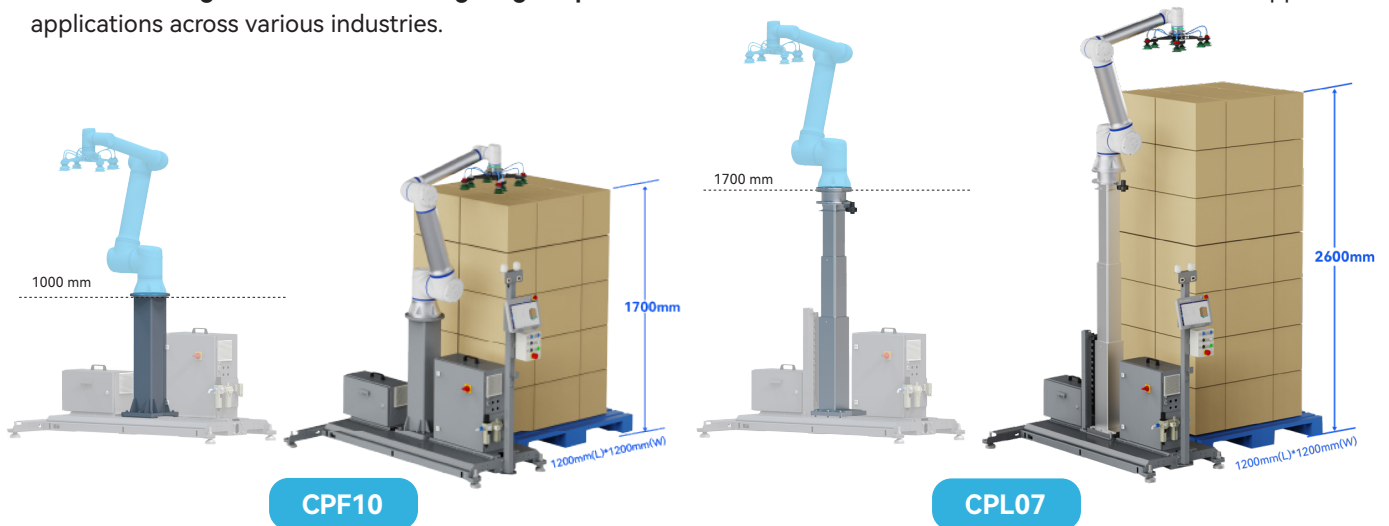

CS SERIES

Robot arm



| | | CS63 | CS66 | CS612 | CS620 | CS625 | CS530H* |
|-------------------------------|-------|--|------------------|-------------------|--|-------------------|-------------------|
| Payload | | 3 kg / 6.6 lb | 6 kg / 13.2 lb | 12 kg / 26.4 lb | 20 kg / 44 lb | 25 kg / 55.1 lb | 30 kg / 66.1 lb |
| Radius | | 624 mm / 24.5 in | 914 mm / 35.9 in | 1304 mm / 51.3 in | 1800 mm / 70.8 in | 1500 mm / 59 in | 1522 mm / 59.9 in |
| Repeatability | | ±0.02mm | ±0.03mm | ±0.05mm | ±0.1mm | ±0.08mm | ±0.1mm |
| Axis | | 6 | | | | | 5 |
| Joints rotation | J1 | ±360° | ±360° | ±360° | ±360° | ±360° | ±360° |
| | J2 | ±360° | ±360° | ±360° | ±360° | ±360° | ±360° |
| | J3 | ±360° | ±360° | ±360° | ±360° | ±360° | ±360° |
| | J4 | ±360° | ±360° | ±360° | ±360° | ±360° | - |
| | J5 | ±360° | ±360° | ±360° | ±360° | ±360° | - |
| | J6 | ±360° | ±360° | ±360° | ±360° | ±360° | ±360° |
| Joints speed | J1-J2 | 180°/s | 150°/s | 120°/s | 125°/s | 125°/s | 125°/s |
| | J3 | 230°/s | 180°/s | 150°/s | 150°/s | 150°/s | 150°/s |
| | J4 | 230°/s | 230°/s | 180°/s | 210°/s | 210°/s | - |
| | J5-J6 | 230°/s | 230°/s | 180°/s | 210°/s | 210°/s | 210°/s |
| Max TCP Speed | | 2.0 m/s | 2.8 m/s | 3.4 m/s | 3.9 m/s | 3.3 m/s | 4.0 m/s |
| IP rating | | IP65 (optional IP68) | | | | | |
| Temperature range | | -10~50°C / 14°F~122°F | | | | | |
| Relative humidity | | <90% (non-condensing) | | | | | |
| Typical power usage | | 185w | 250w | 435w | 625w | 625w | 600w |
| Mounting | | Any orientation | | | | | Front/Reverse |
| Tool I/O connector | | M8, 8pin | | | T1: M8, 8pin T2: Ø 12.8mm, 4pin | | |
| Tool I/O ports | | 4 config. DI / DO; 1 AI, 1 AO | | | | | |
| Tool I/O power supply | | 0 / 12V / 24V; 3A / 2A / 1A | | | T1: 0 / 12V / 24V; 3A / 2A / 1A T2: 24V; 5A | | |
| Tool I/O communication | | RS485 | | | | | |
| Footprint | | 128 mm / 5 in | 150 mm / 5.9 in | 190 mm / 7.4 in | 240 mm / 9.4 in | 240 mm / 9.4 in | 240 mm / 9.4 in |
| Weight | | 15 kg / 33 lbs | 20 kg / 44 lbs | 34 kg / 74.9 lbs | 60 kg / 132.2 lbs | 58 kg / 127.8 lbs | 58 kg / 127.8 lbs |
| Material | | Aluminum, steel, plastic, rubber | | | | | |
| Cable length | | 5.5 m / 216.5 in** | | | | | |
| Programming | | Python-script, graphical proprietary user interface, free-drag/offline programming | | | | | |

* The CS530H robotic arm can only be supplied as part of the CP series palletizing solution.

** Optional cable lengths of 1.5 m (59 in), 3 m (118 in) and 8 m (314.9 in) and additional extensions up to 10 m (393.7 in) are available.

CS SERIES

Controller

| Type | Standard AC | OEM AC / DC |
|-------------------|---|---|
| I/O ports | 24 DI, 24 DO (8 safety config. DI/DO); 2 AI, 2 AO; 4 High-Speed DI | |
| I/O power supply | 24V/3A (internal), 6A (external) | |
| Communication | RS485, Ethernet TCP/IP, Modbus TCP/RTU, Ethernet/IP slave, Profinet slave | |
| Size | 505 mm x 257 mm x 447 mm 19.8 in x 10.1 in x 18.1 in | 495 mm x 200 mm x 227 mm 19.4 in x 7.8 in x 8.9 in |
| IP rating | IP44 | IP40 |
| Weight | 12.5 kg / 27.5 lbs* 15 kg / 33 lbs** | 4.5 kg / 9.9 lbs* 7.5 kg / 16.5 lbs** |
| Power source | 100-240 VAC, 50-60 Hz | AC: 100-240 VAC, 50-60 Hz DC: 19-72VDC* / 40-55VDC** |
| Temperature range | 0~50°C / 32°F~122°F | |
| Relative humidity | 95% (non-condensing) | |
| Material | Aluminum, Steel | |

* For cobots: **CS63 - CS66 - CS612** | ** For cobots: **CS620 - CS625 - CS530H**



CS Series standard AC controller



CS Series OEM controller

Teach Pendant

| Model | ERP400 | ERP400S |
|-------------------|--|--|
| Size | 301 mm x 232 mm x 54 mm 11.8 in x 9.1 in x 2.1 in | 301 mm x 232 mm x 105 mm 11.8 in x 9.1 in x 4.1 in |
| Screen size | 12.1" | |
| Resolution | 1280 x 800 pixels | |
| IP rating | IP54 | |
| Weight | 1.7 kg / 3.7 lbs | 1.8 kg / 3.9 lbs |
| Cable length | 5.5 m / 216.5 in | |
| Temperature range | 0~50°C / 32°F~122°F | |
| Input method | Capacitive full touch-screen | Capacitive full touch-screen, 3-mode enable key, jogging-keys, function keys |

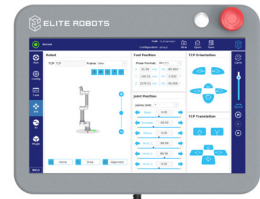

The optional ERP400S TP integrates a 3-modes enable key for enhanced safety

CP SERIES

| BASE | ARM | Payload | Max Pallet Size (W x L) | Max Stacking Height |
|-------|--------|------------------|--|---------------------|
| CPF10 | CS620 | 20 kg / 44 lbs | 1200 mm x 1200 mm 47.2 in x 47.2 in | 1700 mm / 66.9 in |
| | CS625 | 25 kg / 55.1 lbs | 1200 mm x 1000 mm 47.2 in x 39.3 in | 1600 mm / 62.9 in |
| | CS530H | 30 kg / 66.1 lbs | 1200 mm x 1000 mm 47.2 in x 39.3 in | 1600 mm / 62.9 in |
| CPL07 | CS620 | 20 kg / 44 lbs | 1200 mm x 1200 mm 47.2 in x 47.2 in | 2600 mm / 102.3 in |
| | CS625 | 25 kg / 55.1 lbs | 1200 mm x 1000 mm 47.2 in x 39.3 in | 2300 mm / 90.5 in |
| | CS530H | 30 kg / 66.1 lbs | 1200 mm x 1000 mm 47.2 in x 39.3 in | 2300 mm / 90.5 in |

Performance & Common Specs

| | |
|------------------------|--|
| Max Speed | 10 boxes/min (single vacuum cup) 20 Boxes/min (dual vacuum cup) |
| Operating Temperature | 0~50°C / 32°F~122°F |
| Peak Power Consumption | 2~3.5kW |
| Power Source | Single-phase 220VAC/110VAC 50~60Hz |
| Footprint | 1400mm x 1700mm / 55.1 in x 66.9 in |

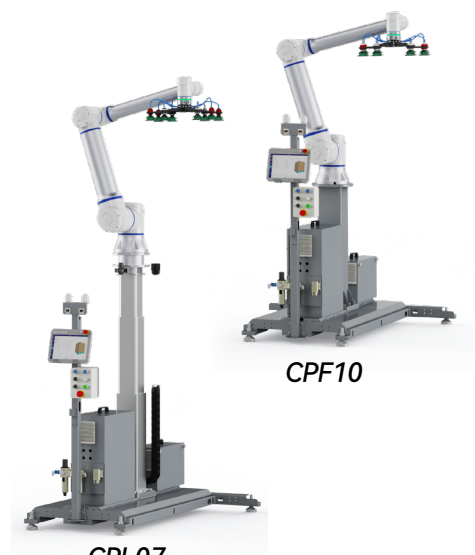

CPF10

CPL07